



BOLTING SOLUTION COMPANY

# SHEAR WRENCH

NEW PRODUCT INFORMATION

## New Shear Wrench for M36 bolt is now available !!

### Heavy Duty

- Hard aluminium body with powered motor.

### Safety Design

- Double insulated structure for user safety.

### Anti-defacement Mechanism

- Original mechanism holds the nut and tip tightly to avoid defacement.



### SHEAR WRENCH

Model	GX-361EZ	GX-362EZ
Frequency	50-60Hz	
Voltage	110-120V	220-230V
Max.Current	12.5A	6.5A
Rated Max. Torque	4000N·m	
Rated Input Power	1400W	
No-Load Speed	2.8min <sup>-1</sup> (rpm)	
Weight (Main Body)	10.1kg	
Adaptable Bolts Dia.	TC bolts (S10T) : M36	
Accessories	Socket Instruction Manual·Metal Case (-)Screw Driver·Connector	



GX-362EZ

\*Weight exclude socket and cord.

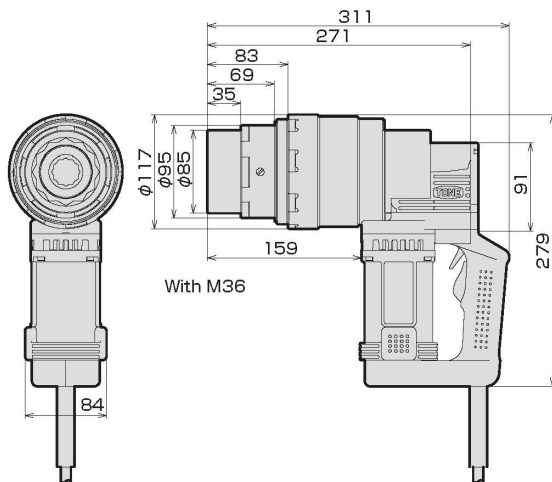

Manufactured by

**TONE** TONE CO., LTD.  
OSAKA, JAPAN.



web site <http://www.tonetool.co.jp>  
e-mail: [overseas@tonetool.co.jp](mailto:overseas@tonetool.co.jp)

Specifications and the design are subject to change without notice.  
TONE is certified to ISO9001:2008 and ISO14001:2004.



Your Distributor



JM Tor Par SA de CV  
Tel. (0155) 5082-0180  
[ventas@jmtorpar.com](mailto:ventas@jmtorpar.com)  
[sales@jmtorpar.com](mailto:sales@jmtorpar.com)

[FLKA014] 14.11.02.TK